

# Effects of the Line Surge on the Gamma Camera

L. David Wells

*The University of Kansas Medical Center, Kansas City, Kansas*

A good constant ac supply is necessary when using a scintillation counting or imaging device. Any ac-line fluctuations and power surges can result in misrepresented counting rate, poor imaging, and possible damage to the instrument.

This articles illustrates: (A) how a line surge immediately after a momentary complete power loss can affect a diagnostic imaging study with the gamma camera; and (B) how to construct an electronic device which will act as a circuit breaker so that there will be no line surge applied to the instrument upon restoration of electrical power.

## Line-Surge Artifacts

Figure 1 shows a pancreatic scan with an artifact. Immediately after the intravenous injection of  $^{75}\text{Se}$ -selenomethionine, 10-min exposures were obtained at 10-min intervals. While the technologist was developing the first 10-min exposure, a

momentary complete power loss occurred within the department. Later, when the technologist developed the second 10-min exposure, he became quite confused when the scintiphoto showed a bright spot in the center of the image just below the lower hepatic border. The departmental engineer was notified and requested to locate the cause of the bright spot. After an hour of checking and intense testing, he failed to reproduce the bright spot on the CRT of the persistence scope. It was decided to accumulate counts and produce an image during the night to see if the same type of artifact could be reproduced. When the Polaroid of the scintiphoto was developed the following morning, the bright spot had reappeared (Fig. 2).

---

For reprints contact: L. David Wells, Radiology Dept., University of Kansas Medical Center, Kansas City, Kans. 66103.

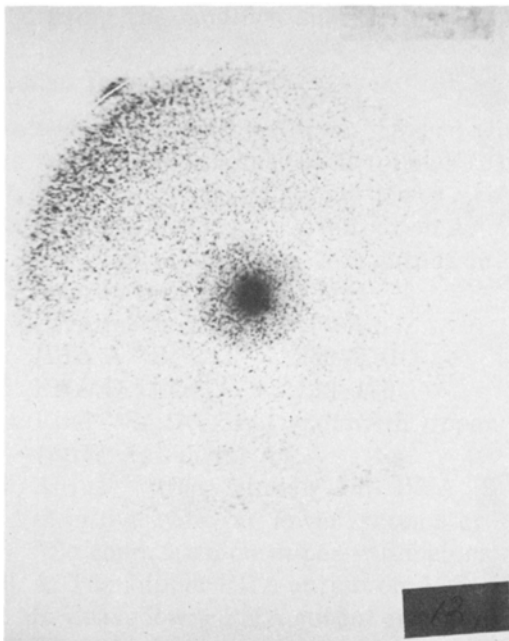

FIG. 1. Scintiphoto demonstrating line-surge bright spot.

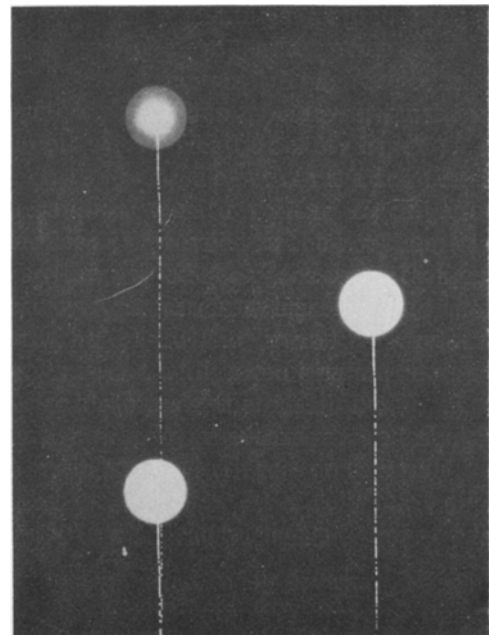

FIG. 2. Bright spot reproduced during overnight image.

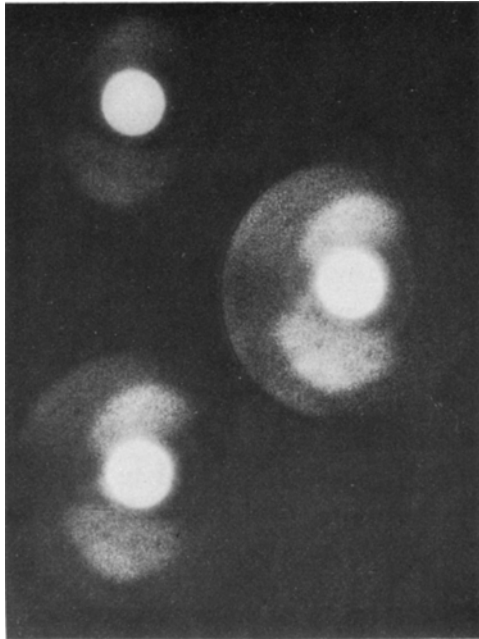

FIG. 3. Scintiphoto showing bright spot appearing during renal scan.

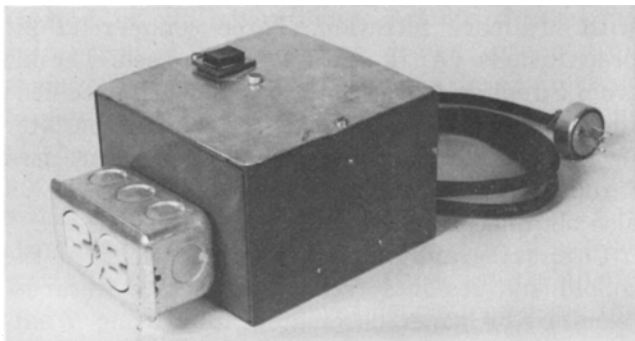

FIG. 4. "Low-voltage drop-off box". Camera is plugged into duplex receptacle on side of box. Three-prong plug is connected into any 117-volt ac wall outlet. Square button on top of box is reset button. Round silver device adjacent to reset button is neon light which, when not lit, indicates open circuit due to voltage drop.

Upon further examination of the camera system, no additional information for the origin or cause of this problem was revealed.

Later the second day while performing a renal scan (Fig. 3) a momentary complete power loss again occurred immediately followed by a line surge. During this procedure, the technologist was facing the console and saw a bright flash in the center of the CRT on the persistence scope. This event and that of the previous day were compared for similarities with the conclusion being that the electrical power fluctuations and subsequently obtained bright-spot photos occurred during electrical storms.

### Electrical Device

To prevent artifacts and possible damage to the scintillation camera from the power surge which

Table 1. Necessary Components for "Low Voltage Drop-off Box"

Qty.	Item
1	PM 17 AY relay 25A 120 V
1	2 amp push button switch
1	117 volt neon bulb
1	Metal box

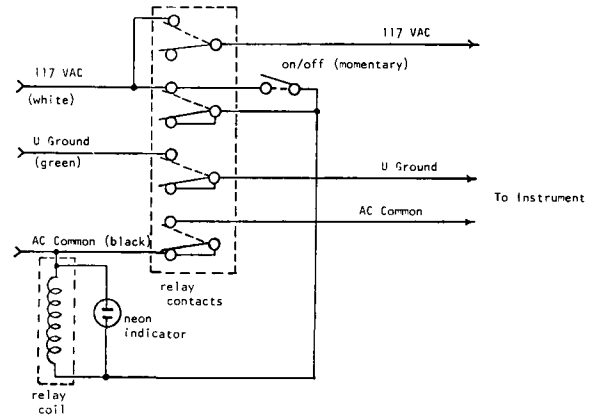

FIG. 5. Schematic diagram of "low-voltage drop-off box". Dotted lines indicate position of relays after resetting box. Solid lines indicate system off.

usually follows a momentary complete power loss or power drop, an electrical device which acts as a circuit breaker was constructed. This simple device, a "low-voltage drop-off box", functions as its name implies (Fig. 4). Similar devices can be constructed at a cost of approximately \$20, and all parts can be easily obtained at almost any electronic store (Table 1). The schematic diagram for this device is given in Fig. 5.

The "low-voltage drop-off box" is used by connecting it into a 117-volt electrical outlet, and the camera power cord is connected into the electrical receptacle located on the side of the box. If a significant power loss occurs, there will be no power surge applied to the scintillation camera when power returns because the circuit is electrically open (Fig. 5).

To return the scintillation camera to normal operation after a power loss, the master control is turned to the "off" position; the "low-voltage trip-off box" reset button is pushed completing the circuit (Fig. 5); and the master control is turned to the "standby" and then "on" position. There will be no line surge applied to the unit, eliminating the possibility of damage to the power supply of the camera and the CRT and the elimination of artifacts on scintiphotos.

### Acknowledgment

I wish to thank Jerry Horne, presently with Siemens X-Ray Company, former departmental engineer, and Lee Knapp for their technical assistance.